

71 63 151 Installing LED turn signal light

+ 71 63 651

Status:

08.2007

Preparatory work

=> Removing and installing the rear-wheel stand special tool (motorcycles without centre stand) (Description in item: 46 52 510, Billed as a separate item)
Removing seat

Core activity

(-) Removing left flashing turn indicator

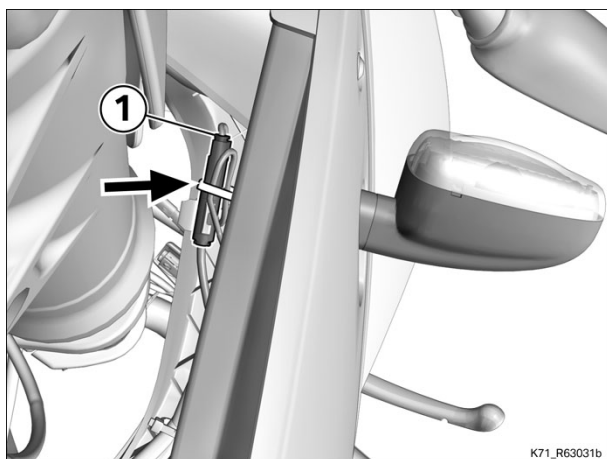

- Open the cable tie (arrow).
- Disconnect plug (1).

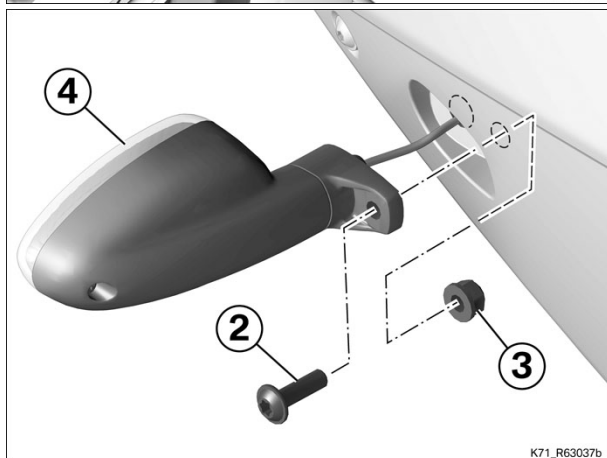

- Remove screw (2) with nut (3).
- Remove flashing turn indicator (4), carefully working the plug clear of the motorcycle.

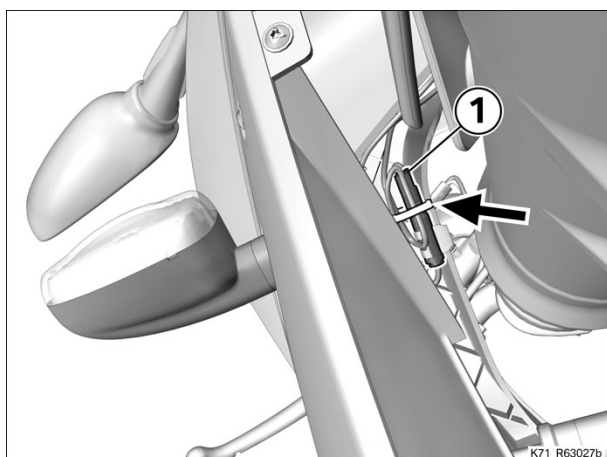

(-) Removing right flashing turn indicator

- Open the cable tie (arrow).
- Disconnect plug (1).

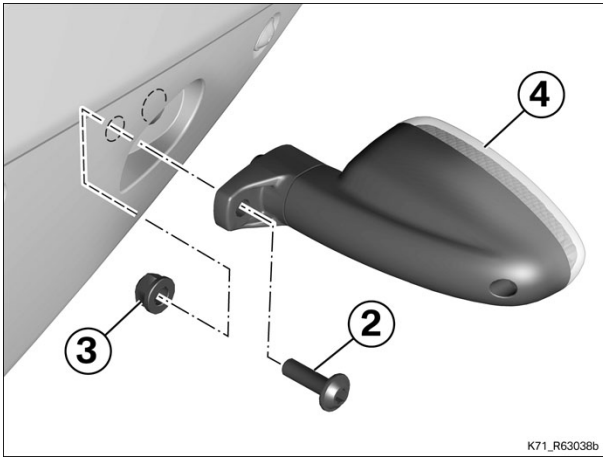

Remove screw (2) with nut (3).

- Remove flashing turn indicator (4), carefully working the plug clear of the motorcycle.

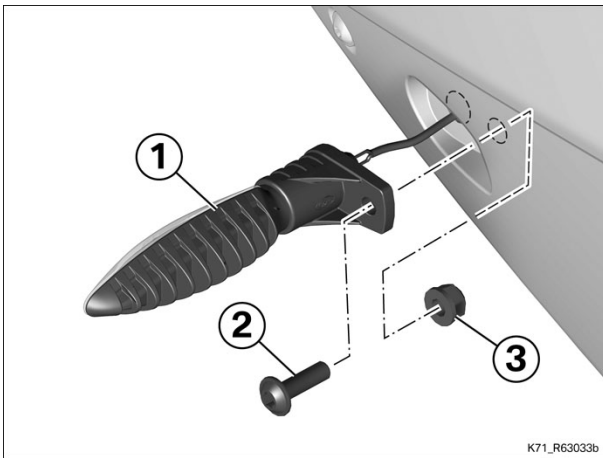

(-) Installing left LED turn indicator

- Work the LED turn-indicator cable with plug into position and hold flashing turn indicator (1) in position.
- Install bolt (2) with nut (3).

 Tightening torques		
Flashing turn indicator to side panel, front		
	2 Nm	

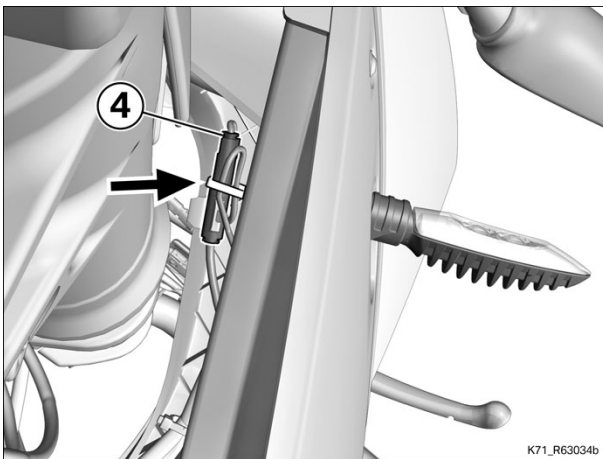

- Connect plug (4) and use a cable tie (arrow) to loop back the excess length of cable at the point of disconnection.

(-) Installing right LED turn indicator

- Work the LED turn-indicator cable with plug into position and hold flashing turn indicator (1) in position.
- Install bolt (2) with nut (3).

 Tightening torques		
Flashing turn indicator to side panel, front		
	2 Nm	

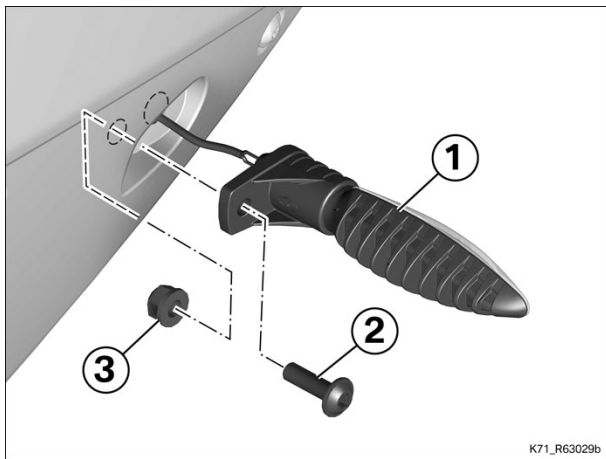

K71_R63029b

- Connect plug (4) and use a cable tie (arrow) to loop back the excess length of cable at the point of disconnection.

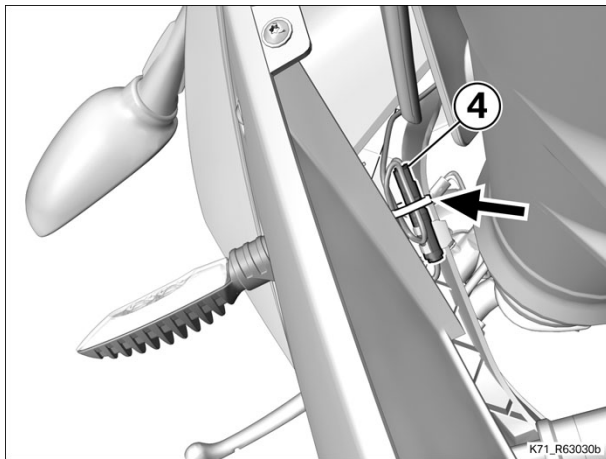

K71_R63030b

(-) Removing rear flashing turn indicator

- Open cable tie (arrow).
- Disconnect plug (1).
- Remove screw (2).
- Remove flashing turn indicator (3), carefully working the plug clear of the motorcycle.

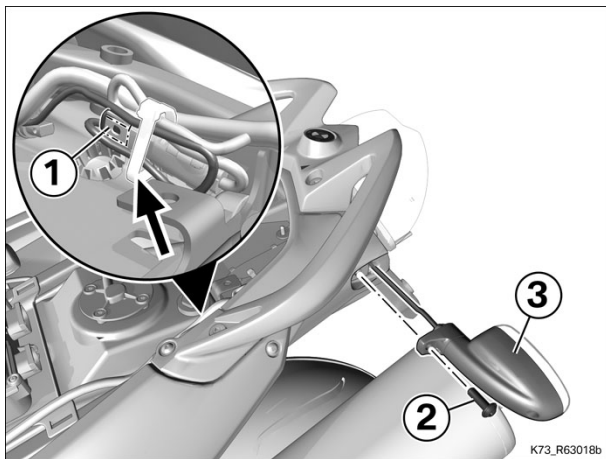

K73_R63018b

(-) Installing complete LED rear flashing turn indicators

- On each side, work the LED turn-indicator cable complete with plugs into position.
- Hold turn indicator (1) in position and install screw (2).

 Tightening torques		
Flashing turn indicator to rear trim panel		
M6 x 20	2 Nm	

- Connect plug (3) and use a cable tie (arrow) to loop back the excess length of cable at the point of disconnection.

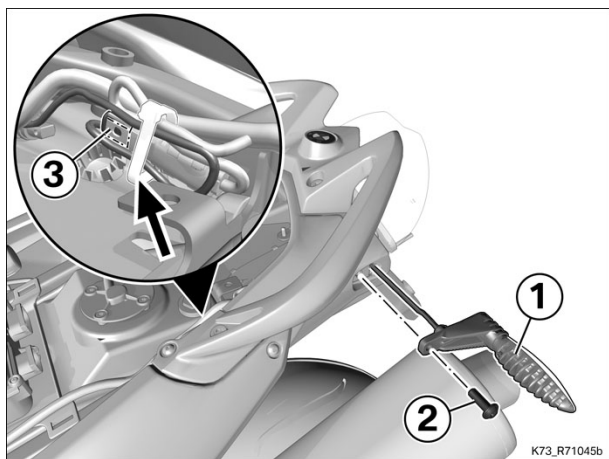

Finishing work

Connecting **BMW Motorrad** diagnostic system to motorcycle

Preparing motorcycle for **CIP** (coding, individualisation and programming)

Disconnecting BMW Motorrad diagnostic system from motorcycle

Installing seat

Final check of work performed